



June 1, 2010

## FIRE RING INSTALLATION INFORMATION

5061 Brooks St., Suite B  
Montclair, CA 91763

(800)-527-4790

Fax (800)-758-2929

www.sierraproductsinc.com

### STANDARD MASONRY FIRE PIT

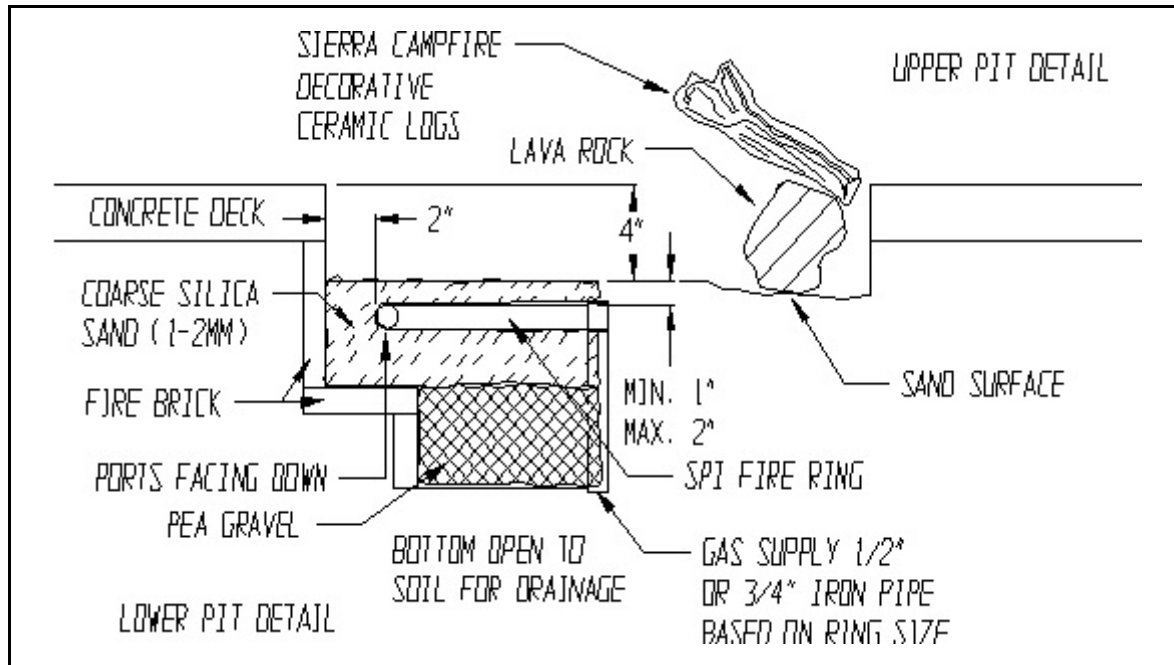

#### GENERAL INFORMATION - OUTDOOR FIREPITS

Outdoor firepits are constructed of standard masonry materials including firebrick, poured in place concrete, or various other natural non-combustible materials. Use care when selecting the materials to assure any materials that may come in contact with the flame area will not cause cracking or expansion. Check with your local material yard for best materials.

#### GAS PIPING AND CONSTRUCTION

Basic pipe installation requires a natural gas supply pipe to be buried in accordance with local codes and attached to an approved shut off valve. The pipe is brought vertical into the center of a firepit. Most pits are round however any shape can be used. The bottom of the pit is open to soil for water drainage while the sides are firebrick. The overall depth can vary however the basic dimensions are shown in Figure 1. Remember to place your pit from combustible construction. Use the chart below to estimate BTU and gas pipe requirements.

#### BTU BURN RATE FOR NATURAL GAS BASED ON INLET PRESSURE W/C.

DESCRIPTION	P/N	4.0 IN.W.C	5.0 IN.W.C	6.0 IN.W.C	7.0 IN.W.C
12" FIRE RING - SINGLE RING	10839	71,401	80,838	87,980	94,541
18" FIRE RING - SINGLE RING	10840	80,278	90,888	98,917	106,294
22" FIRE RING - DOUBLE (12" INNER)	10841	90,496	102,457	101,850	101,850
24" FIRE RING - DOUBLE (12" INNER)	10842	104,083	117,840	128,250	137,814
30" FIRE RING - DOUBLE (18" INNER)	10843	124,020	140,412	152,816	164,212
36" FIRE RING - DOUBLE (18" INNER)	10844	136,095	154,082	167,694	180,199

NOTE: RATES 12",18",22" BASED ON 1/2" RIDGED SUPPLY PIPING 30' FROM SOURCE

RATES 24",30",36" BASED ON 3/4" RIDGED SUPPLY PIPING 30' FROM SOURCE

#### INSTALLATION

Fire-ring is installed with the port holes down. Fill bottom of pit with pea gravel to within several inches of the burner. Cover burner with about 2" of coarse (1mm-2mm) silica sand. The sand disperses the gas and allows for a large area burn. Top sand with volcanic rock and/or SPI's **Sierra Campfire Logs** available through your local dealer. For further information please contact contact Customer Service at (800)-527-4790, Monday thru Friday 8am-4:30pm PST.